

DIGISYNTHETIC[®] PRO

DIGITAL SPEAKER PROCESSOR MODEL DS216A

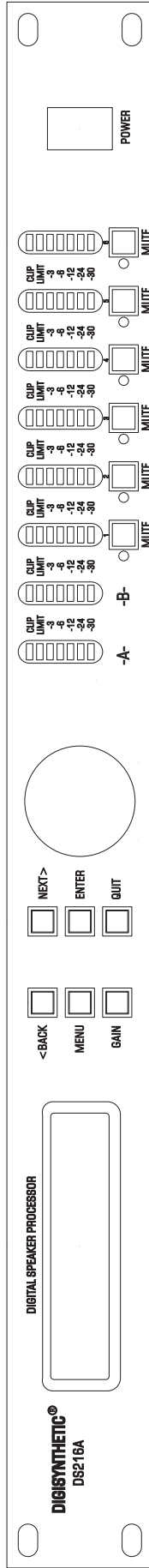

DS216A

DS214A

INSTRUCTION MANUAL

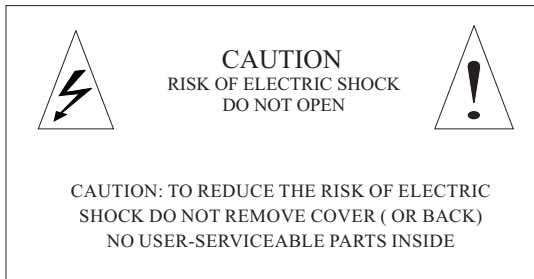

The lightning flash with arrowhead symbol within an equilateral triangle is intended to alert the user to the presence of uninsulated dangerous voltage within the product's enclosure, that may be of sufficient magnitude to constitute a risk of electric shock to persons.

The exclamation point within an equilateral triangle is intended to alert the user to the presence of important operation and maintenance (servicing) instruction in the literature accompanying the appliance.

IMPORTANT SAFTY INSTRUCTION

Please see below basic protection proceeding before using:

1. Please read all the safty instruction before using the product.
2. This product must be earthed. If it should be malfuction or break down, grounding provides a path of least resistance for electric current to reduce risk of electric shock.

This product is equipped with a cord having an equipment-grounding conductor and a grounding plug. The plug must be plugged into an appropriate outlet that is properly installed and earthed in accordance with all local codes and ordinance.

DANGER- Improper connection of the equipment-grounding conductor can result in a risk of electric shock. Check with a qualified electrician or serviceman if you are in doubt as to whether the product is properly grounded. Do not modify the plug provided with the product - if it will not fit the outlet, have a proper outlet installed by a qualified electrician.

3. To reduce the risk of injury, close supervision is necessary when the product is used near children.
4. Do not use this product near water-for example, near a bathtub, waxhbowl, kitchen sink, in wet basement or near a swimming pool or the lake.
5. This product may be capable of producing sound levels that colud cause permanent hearing loss. Do not operate for a long period of time at high volume level or at a level that is uncomfortable. If you experience any hearing loss or ringing in the ears, you should consult an audiologist.
6. This product should be located so that its location or position does not interfere with its proper ventilation.
7. This product should be located away from heat sources such as radiators, heat registers or other products that produce heat.
8. The product should be connected to a power supply only of the type described on the operation instructions or as marked on the product.
9. This product may be equipped with a polarized line plug (one blade wider than the other). This is a safty feature. If you are unable to insert the plug into the outlet, contact an electrician to replace your obsolete outlet. Do not defeat the safety prupose of the plug.
10. The power-supply cord of the product should be unplugged from the outlet when left unused for a long period of time. When unplugging the power-supply cord, do not pull on the cord, but grasp it by the plug.
11. Care should be taken so that object do not fall and liquid are not spilled into the enclosure through opening.
12. The product should be serviced by qualified service personnel when:
 - A. The power-supply cord or the plug has been damaged; or
 - B. Objects have been fallen, or liquid has been spilled into the product; or
 - C. The product has been exposed to rain; or
 - D. The product does not appear to operate normally or exhibits a marked change in performance; or
 - E. The product has been dropped or the enclosure damaged..
13. Do not attempt to service the product beyond that described in the user-maintenance instructions. All other servicing should be referred to qualified service personnel.
- 14 **WARNING-** Do not place objects on the product's power cord or place it in a position where anyone could trip over, walk on or roll anything over it. Do not allow the product to rest on or to be installed over power cords of any type. Improper installations of this type create the possibility of fire hazard and/or personal injury.

SAVE THESE INSTRUCTIONS

FEATURES

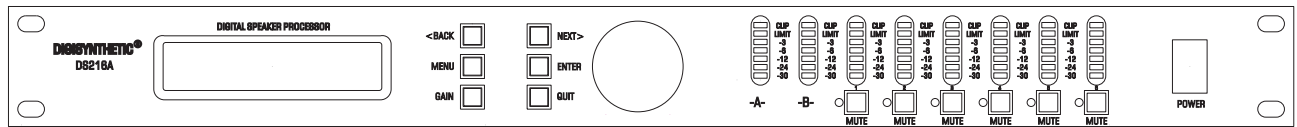

Main features:

- ★DS216A/DS214 are based on DSP technology speaker processor, high functional AKM A/D Ak5392
- ★3pcs 24 bit high precision DSP
- ★Low distortion, high dynamic, frequency: 20Hz~20kHz
- ★DS216A is 2 input, 6 output, include 5 configure model: 2×2way, 2×3way, 4way, 5way, 6way。
- ★DS214A is 2 input, 4output, include 4configure model: 2×2way, 3way, 4way, 2way sub.
- ★Each model include input gain control, each channel include separate crossover controller。
- ★5 band parameter equalizer, delayer, maxim delay 7ms,
- ★Output gain and phase control, parameter lock to avoid misoperation.
- ★Rs232 interface remote control, include PC software.
- ★Each group parameter equalizer has 31 (ISO) frequency, -12dB to +12dB gain.
- ★Each group Q value is from 0.5 to 10, and provide Hi_shelf, Lo_shelf select funtion.
- ★Separate limiter: Attack, Hold, Decay and threshold parameter for flexible configuration.
- ★Each channel configure high pass, low pass 6dB, 12dB, 18dB, 24dB, 48dB Butterworth、Linkwitz riley Bessel frequency response curve。
- ★8×7 bit input/output precision digital LED meter.
- ★2×20LCD backlit。

FRONT PANEL

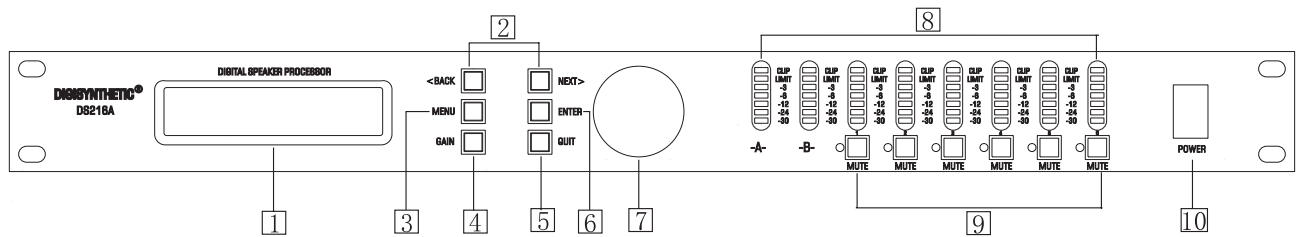

- 1、LCD: display menu and parameter
- 2、<BACK/NEXT>: direction shift button: switch the menu, adjust parameter value in some menus.
- 3、MENU: menu adjustment button。
- 4、GAIN: gain and parameter adjustment button, push the button again to switch the channel.
- 5、QUIT: quit the menu。
- 6、ENTER: confirm button。
- 7、Param: parameter switch and adjustment.
- 8、Input,Output input/output LED meter。
- 9、Output channel mute button。
- 10、POWER: ON/OFF power switch。

Rear panel

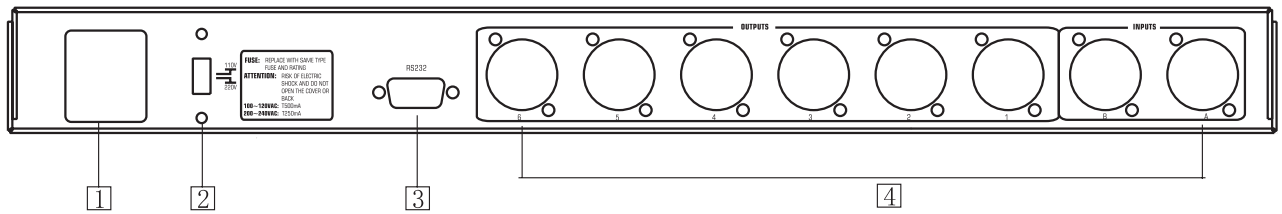

- 1、 Power Jack:
- 2、 Voltage adjustment switch: 110V~220V。
- 3、 RS232 interface。
- 4、 XLR input and output terminal。

OPERATION

1、 Xover Submen

Push "MENU" button, use "BACK" "NEXT" "ENTER" to adjust X-OVER submenu, include:

Load a xover: adjust a stored mode.

Design a xover; design a xover mode, include a mode type, stereo connect control, input channel adjustment.

Store a xover: Store all output setting of a X-OVER. There are 10 user memory. Each memory may have a name contains 16 letters. If the memory name is not edited, it is stored under the corresponding mode name.

Erase a xover: Deltete a stored mode.

2、 Security submenu

Push MENU botton, adjust Security Submenu by “BACK” “NEXT” , “ENTER” The locking mode as follows:

Change only: Parameters can be viewed, can not be adjusted. MUTE is valid

Change +View: Parameters can not be viwed, can not be adjusted. MUTE is valid.

Change +Mutes: Parameters can be viwedd, can not be adjusted. MUTE is not valid

Everything: Parameters can not be viwed, can not be adjusted. MUTE is not valid.S

Select a lock type and push “Enter” button

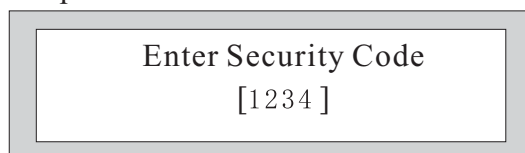

Enter Security Code
[1234]

A) Push “BACK” & “NEXT” shift the cursor, turn round PARAM to change the character.

B) Push “ENTER, confirm the password and display as follows.

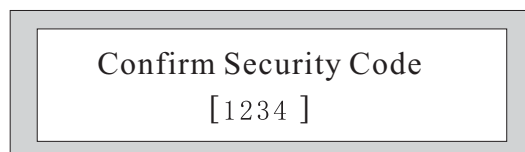

Confirm Security Code
[1234]

C) Repeat procedure A and push ENTER button.

D) System is locked when the password is same, or the locking operation is invalid.

3, SYSTEM SUBMENU

Push MENU botton, adjust Security Submenu by “BACK” “NEXT” , “ENTER” SystemSubmenu as follows:

Input option: setting A, B input link control channel.

OPERATION

Wake up time

Fade-in: Volume rise to memory mode slowly.

Mute hold: all channels are mute.

Delay Time/distance: Delay unit display.

Time(ms)

Metres

Feets

4、Interface submenu

Interface submenu include: RS232 baud rate and address code setting. Select 2400、4800、9600、19200、38400 baud rate according different PC.

Remote ID NUM: 1~32。

5、Parameter

Push “Gain” to enter setup menu, push “Back” “Next” to switch menu, rotate “Param” to adjust parameter.

A、Input gain: Input A、Ipput B, Gain adjust range is 40.0dB~+6.0dB, ± 0.5 dB.

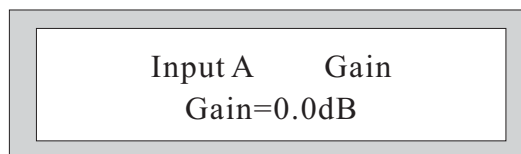

Input A Gain
Gain=0.0dB

B、Output gain: Op1……Op6.

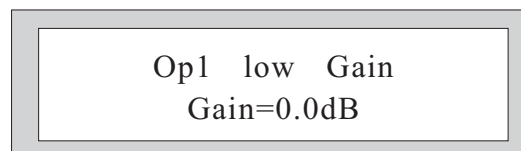

Op1 low Gain
Gain=0.0dB

C、Output phase: Polanty, [+], [-].

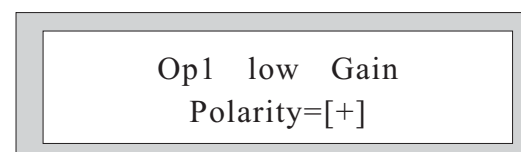

Op1 low Gain
Polarity=[+]

D、Delay: adjustment range is 0ms~7ms, -0.5ms.

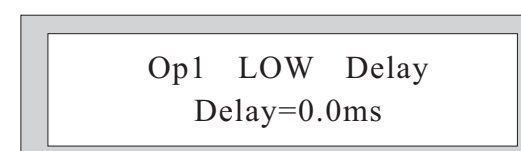

Op1 LOW Delay
Delay=0.0ms

OPERATION

E、HPF&LPF

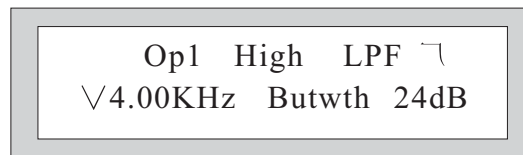
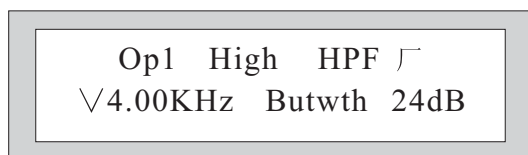

Push_Param button to change parameter indicator “√” position, rotate Param button to change parameter.

Highpass: frequency range <10Hz~16.0KHz

Low pass: frequency range 35Hz~22.0KHz

F、PEQ

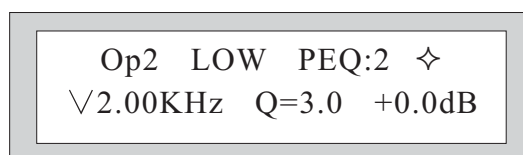

Push_Param button, move “√” indicate parameter, rotate Param to adjust parameter.

Note: in PEQmenu, “Enter” is used for “Bypass” .

“✧” means PEQ

“}” means Loshelf

“{” means Hishelf

“=” means PEQ Bypass

Freq: 20Hz~20.0kHz (31个ISO)

Q: 0.5~10 (Hishelf、Loshelf)

Gain: -12dB~+12dB (±1dB)

Hishelf: 1.0K~20.0kHz

Loshelf: 20.0Hz~1.0kHz

Note: when using Hishelf、Loshelf, set Gain=0.0dB, change Qvalue to Hishelf/Loshelf.

G、Limiter

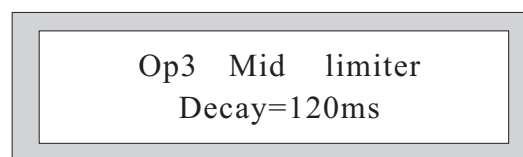
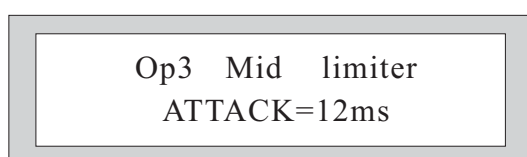
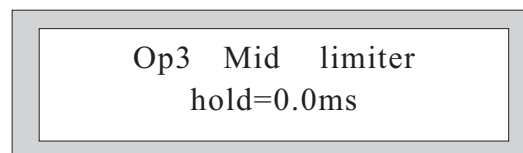
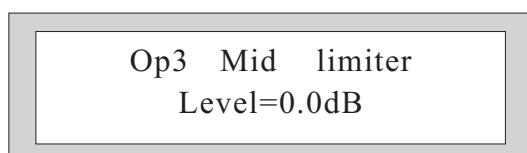

OPERATION

Limiter include: LEVEL (-20dB~+15dB), attack (1~100)ms. HOLD (0~1000)ms.
DECAY(0~1000)MS.H, Name of channel: Rotate Param to change the channel name.

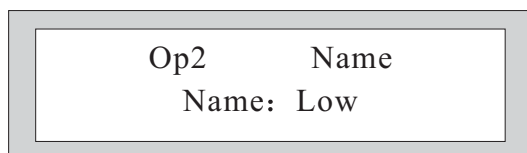

I, Input signal

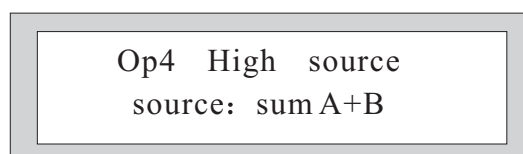

In this menu, LCD displays current input channel. Parameter can't be adjusted,
can be check.

DS216A 2X2 WAY+MSUM

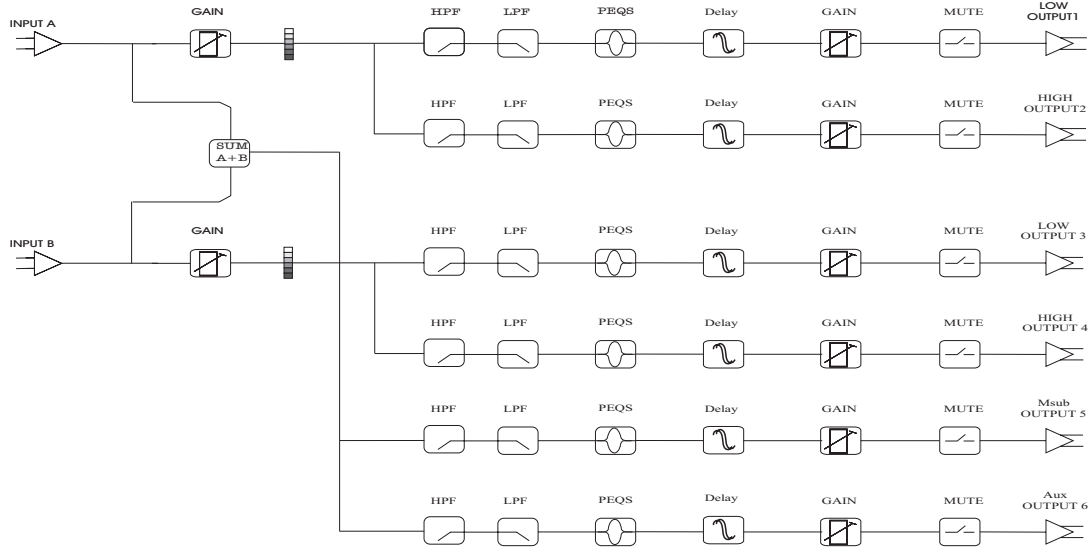

DS216A 2X3 WAY

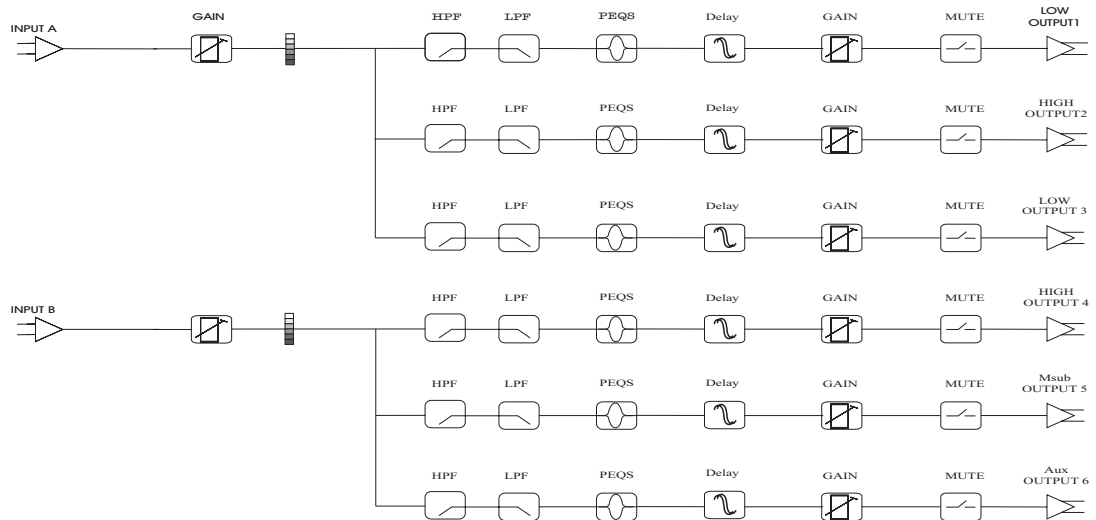

DS216A 4WAY+2AUX

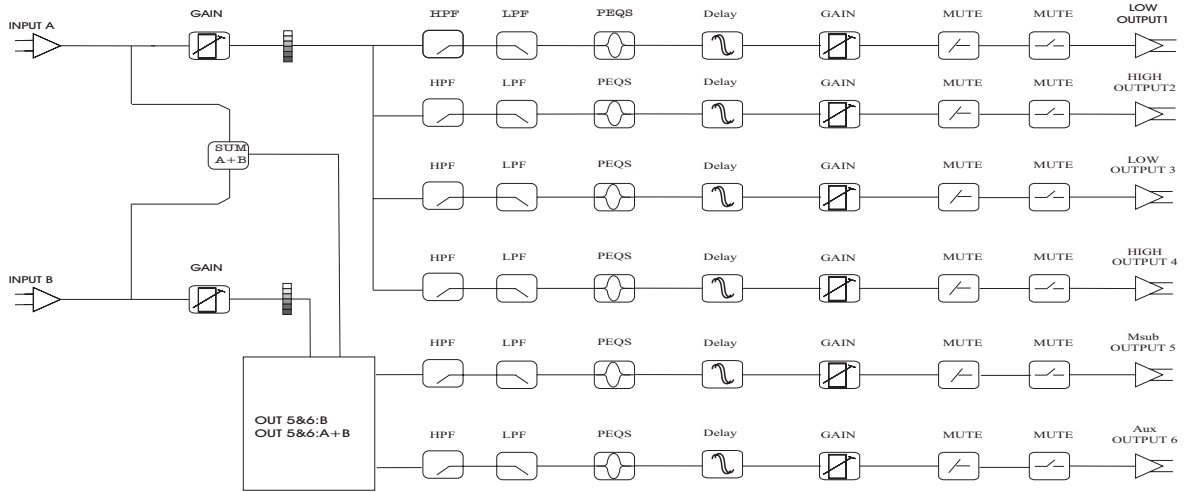

DS216A 5WAY+1AUX

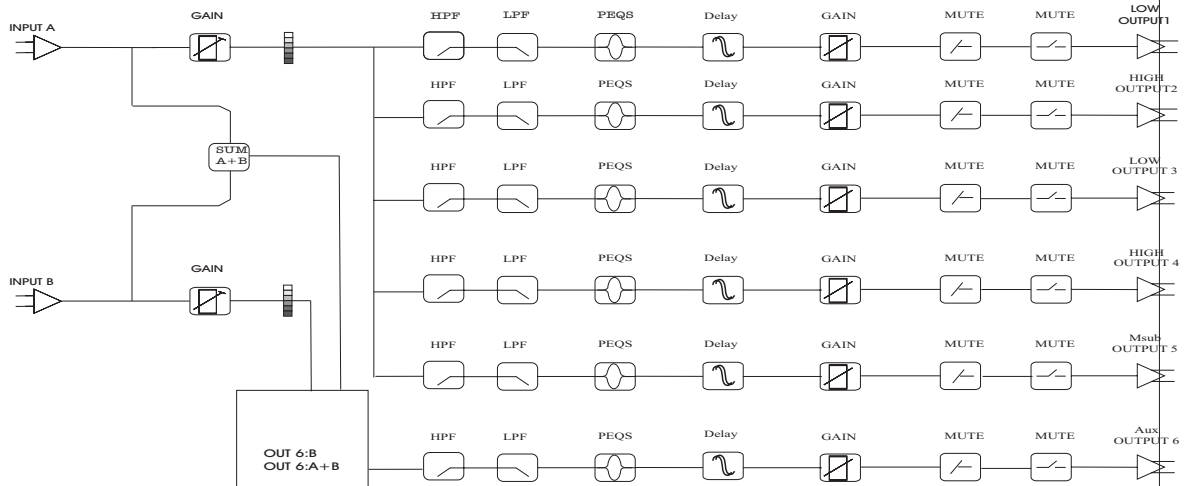

DS216A 6WAY

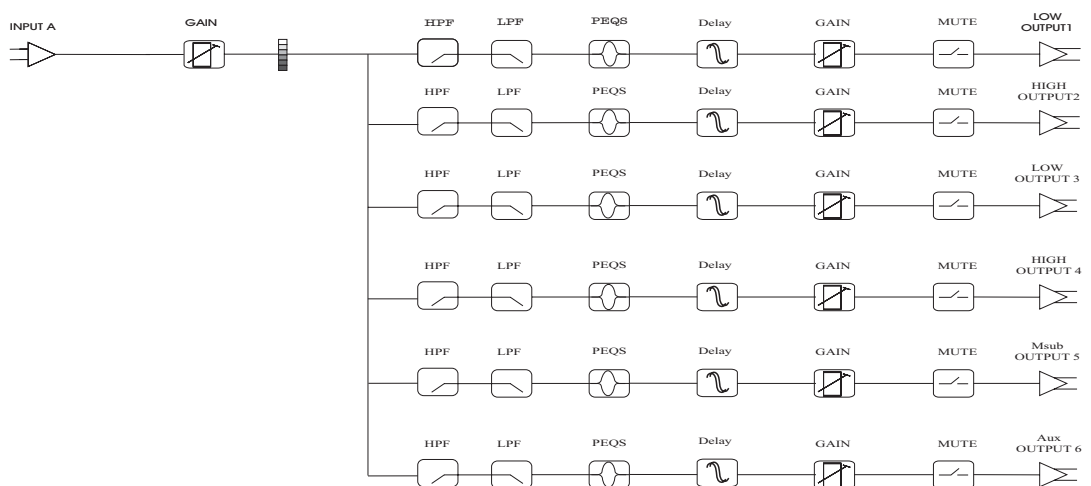

OPERATION

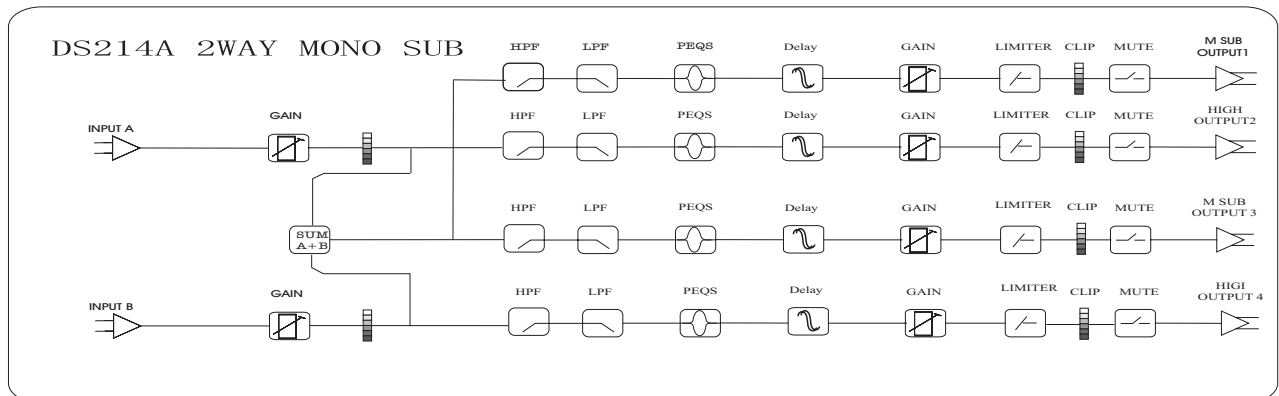
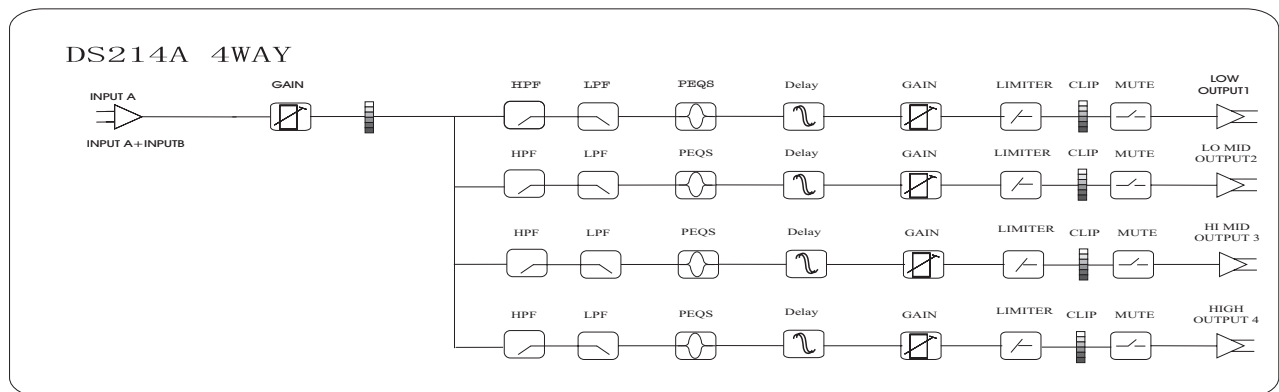
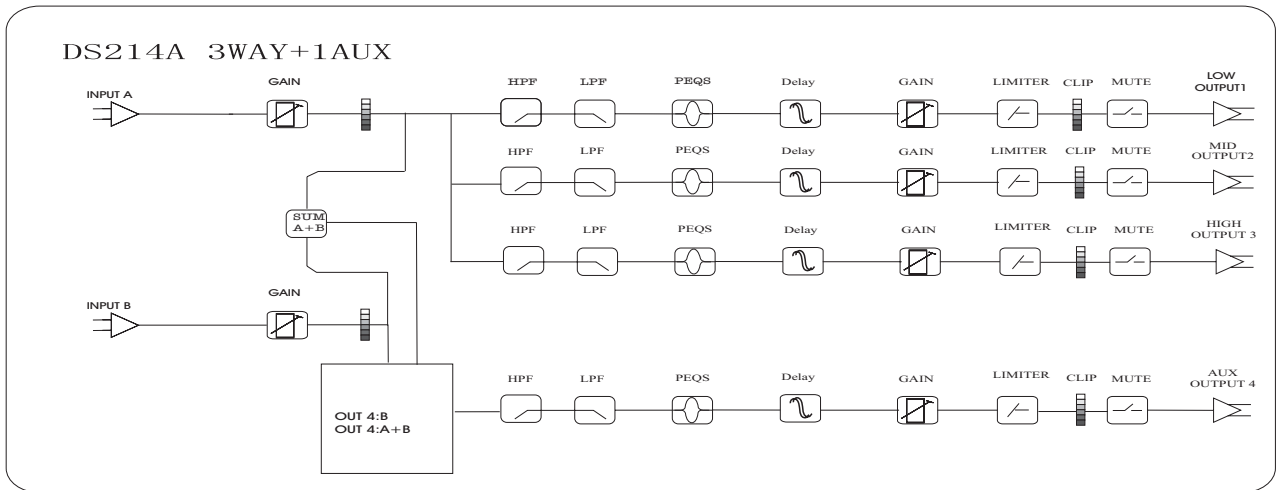
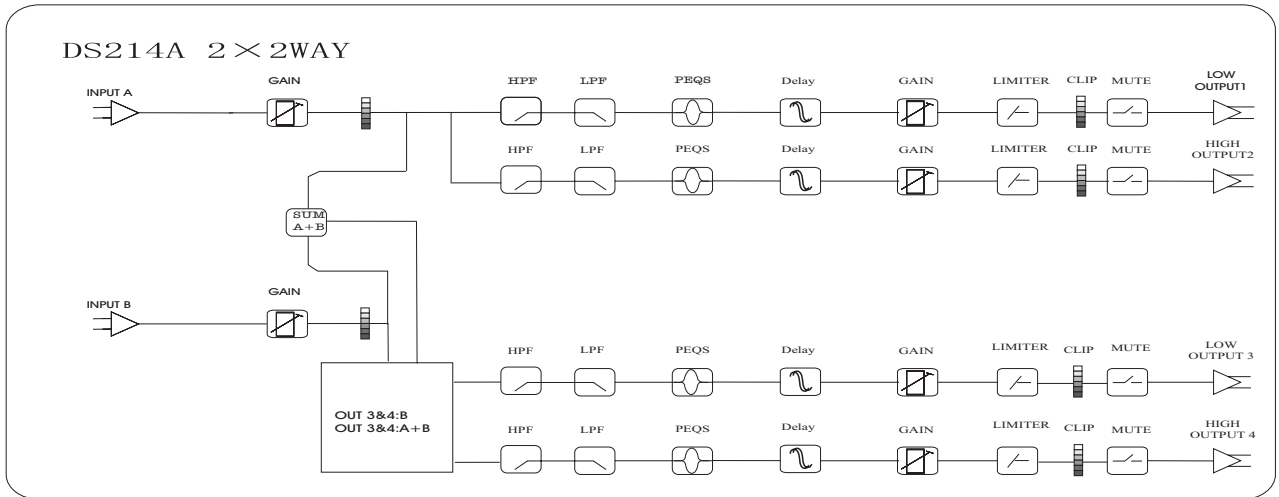

Input	
Impedance	10K Ω
CMRR	>50dB (30Hz~20KHz)
Output	
Impedance	<50 Ω
Maxim output electrical level	Vpp=4V , Vpp=7.6V
Frequency Resp.	20Hz~20.0kHz
Dynamic Range	
Distortion	0.01%(THD)
Mixman Delay	7ms
Output gain	-40dB~+6dB ± 0.5 dB
Input gain	-40dB~+6dB ± 0.5 dB
Parametric Equalizer	
Filter	
Gain	± 12 dB in 1dB steps
Central Freq.	20Hz~20kHz 31 ISO
Q value	0.5~10
Shelving	
Lo-shelf:	20Hz~1kHz
Hi-shelf:	1kHz~20kHz
Shelf gain:	± 12 dB in 1dB steps
HPF&LPF	
Filter	
Frequency (high pass)	<10Hz~16.0kHz
Frequency (low pass)	35Hz~22.0kHz
Response curve	Butterworth 6dB、12dB、18dB、24dB、48dB Bessel 12dB、18dB、24dB、48dB Linkwitz-Riley 24dB、48dB
Limiter	
Level	-20~+15dB
Attach time	1~100ms
Holding time	0~100ms
Decay time	10~1000ms
LCD	2 \times 20
Input LED	-30dB,-24dB,-12dB,-6dB,-3dB,Limit,Clip
Output LED	-30dB,-24dB,-12dB,-6dB,-3dB,Limit,Clip
Connectors	
Input	XLR-3F
Output	XLR-3M
Rs232	
Power	-220V/AC 50Hz, 110V/AC 50Hz
Weight	3.6KG
Size	480mm \times 44mm \times 220mm